

Decomatic® DA2000

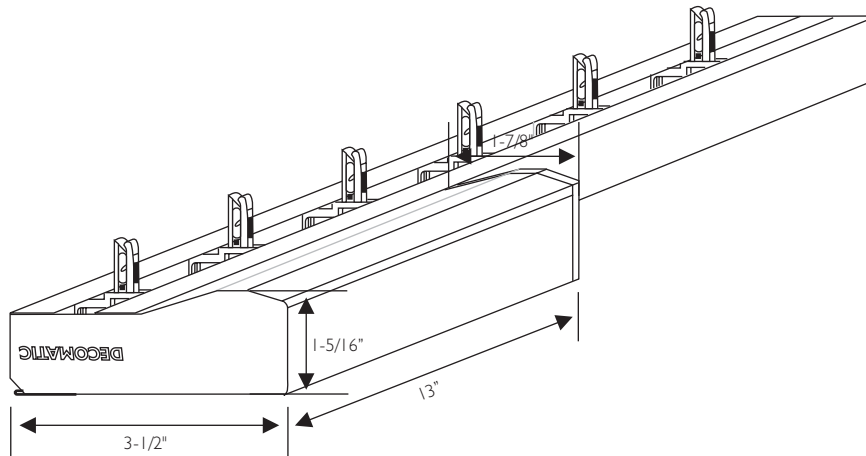

The Decomatic motorized vertical, DA2000, is a totally integrated motorized vertical system. The microprocessor controlled drive system features easy push button controls and minimal space requirements.

PRODUCT SPECIFICATIONS:

Minimum Width: 15"

Maximum Width: 240"

Maximum Blind Weight: 65 lbs.

Maximum Vane Weight: 1-1/4 lbs.

Extrusion Color: Clear Anodized, White

Vane Spacing Available: 2", 3-1/2", 4", 5" and custom sizes up to 8"

Control Options: Wall Switch, IR (infrared), RF (radio), Sun Sensor, Timer

Motor Location: Left rear

Stack Options: One-Way, Split, Center

Input Voltage: 12v

Power Consumption: 0.2-1.0 A

Tractive Power: 140 N

Torque of tilt: 30 Ncm

Traverse Speed: Approximate 10' per minute

Multiple Connections: Up to 40 blinds can be linked together to operate as one unit

Decomatic Heavy Duty Vertical System

The word "Decomatic" consists of Decorative and Automatic. As a product, it is the first vertical blind system worldwide that was specially designed to be processed on automatic equipment. And, best of all, it is loaded with unique features to give years of trouble free service.

General Specifications

General - Heavy-duty vertical track system capable of rotating and traversing at widths up to 240" for residential and commercial applications. The hook replacement feature is provided with all Decomatic tracks.

Operation - Cord, Wand, DA2000 low voltage motor, DA1000 battery operated motor. Available stack configurations: one-way, split, center, opposite and off-center.

Specialty Applications - Curve (horizontal bend), Arch (vertical bend), Motorized, Slope (angle), Skylight, Top and Bottom track (wall mounted).

Head Rail - Made of extruded aluminum alloy 6063-T5, 1-1/2" wide X 1" high. The extrusion has a normal wall thickness of .045" Available finishes are Clear Anodized, White and Bronze powder coated.

Tilt Shaft - Made of extruded aluminum alloy 6063-T5, 1/4" diameter, single groove.

Carrier - Each carrier is 5/16" wide with two wheels, molded of self lubricating plastic such as Celcon. The carriers have a geared clutch system for overload protection and a steel clutch spring to reinforce positive action. There also is a unique stabilizer bar designed to fit into the extruded slot in the aluminum head rail to provide smooth traversing along the width of the head rail. The hooks of the carrier are made of clear, high ultra-violet resistant Lexan and are replaceable even while the unit is installed. The carriers provide the vanes with 185° rotation capability to provide full vane closure and will stay in position unless reset. Maximum vane weight 1-1/4 pounds.

Control Chain - The control chain is made of Celcon beads molded onto a nylon cord or #6 metal chain. One full cycle of the control chain (13-1/2") will self align the vanes.

Spacer Links - The spacers, made of flexible, corrosion proof, stainless steel, are interlocked between carriers to provide smooth traversing. Spacers are 6.03mm x .19mm. Spacing systems are designed for 2", 3-1/2", 4" and 5" vane widths. Special spacing is available up to 8", upon request. Spacing is equal on all vane widths.

End Caps - All Decomatic tracks are manufactured with completely covered end caps, concealing internal parts for a custom, finished appearance. The end caps are molded of self lubrication plastic such as Celcon and their unique design allows for only 1/4" light gap on the control end of a inside mount vertical. The Decomatic system is available with standard direct drive 1-to-1 rotation mechanism (13-1/2" of control chain required to rotate 180°), or a 4-to-1 ratio rotation mechanism (46" of control chain required to rotate 180°).

Stack - 5/16" wide carrier and 1/4" light gap end cap allows for very tight stacking. 122" one-way draw track stacks in 15" of space.

Decomatic® Head Rail

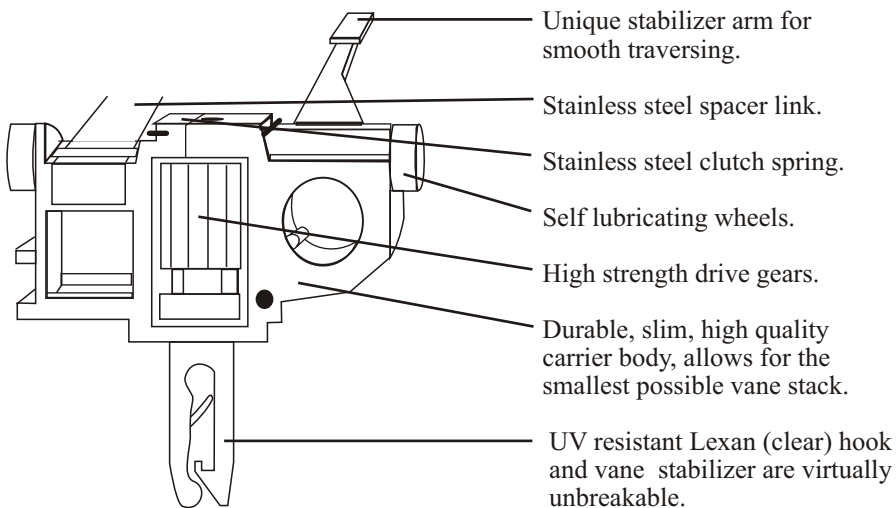
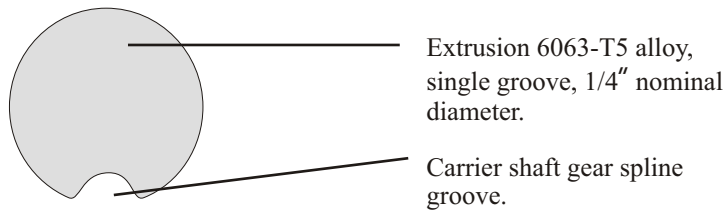
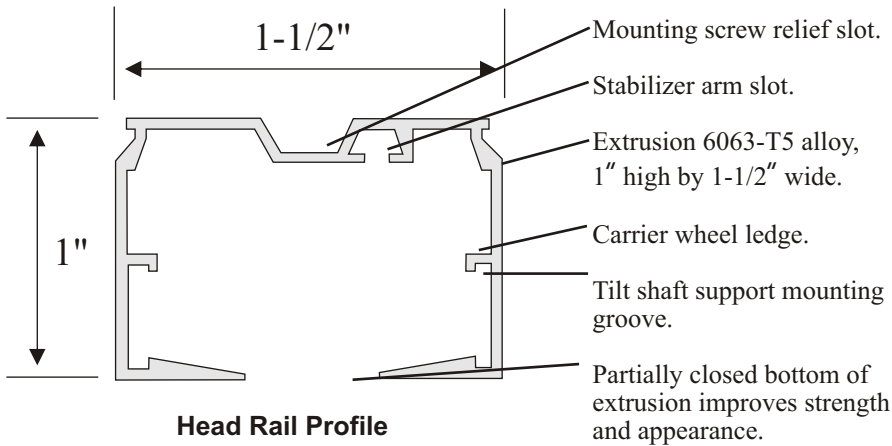

Features and Benefits

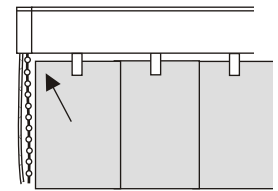

Tight 1/4" light gap on the control side of inside mount blinds.

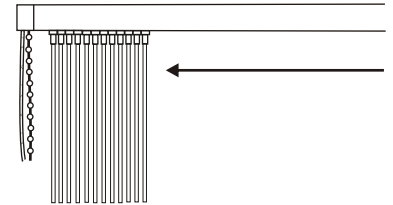

Tightest stacking available for a clean, custom fit.

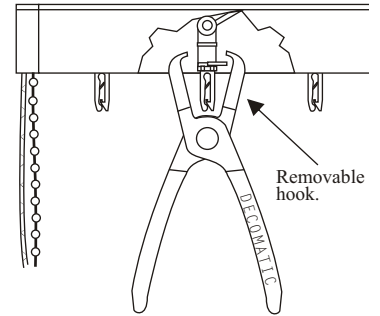

Removable hooks with hook removal pliers, without un-mounting head rail.

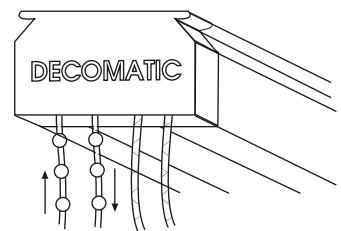

Automatic clutch protected vane alignment by simply rotating the beaded rotation chain 180 degrees in each direction.

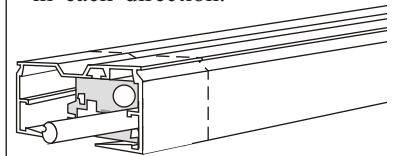

Easy cut down without special tools or the removal of push nuts.

Decomatic[®] Warranty

Sunteca Systems, Inc. ("Company") warrants that its Products will be free from defects in materials and workmanship, under normal use and service and subject to the conditions set forth below, for the following respective time periods:

HEAD RAIL: LIFETIME LIMITED WARRANTY

Company warrants that its Head rail sold hereunder will substantially conform to the applicable specifications and will be free from defects in material and workmanship for the life of the Head rail, under normal and proper use and service.

BLIND VANES/FABRIC/PVC: 3 YEAR LIMITED WARRANTY

Company warrants that its blind louvers, or fabric, or PVC sold hereunder will substantially conform to the applicable specifications and will be free from defects in material and workmanship for a period of three (3) years after date of purchase, under normal and proper use and service.

ELECTRICAL COMPONENTS: 2 YEAR LIMITED WARRANTY

Company warrants that its Electrical components sold hereunder will substantially conform to the applicable specifications and will be free from defects in material and workmanship for a period of two (2) years after the date of purchase, under normal and proper use and service.

WARRANTY LIMITATION. This limited warranty and remedies for breach of warranty extend only to the ultimate owner at the original site of installation and do not cover, and Company shall not be liable for, (i) abnormal wear and tear or damage caused by improper installation, maintenance or use contrary to the instructions published by Company (ii) storage of Products in a wet or damp area or unprotected from weather and other job conditions (iii) any cause beyond the control of Company, including without limitation conditions caused by movement, settlement or structural defects of building in which the Products are installed, fire, wind, hail, flood, lightning or other acts of God, intentional acts, accidents, negligence or exposure to harmful chemicals, pollutants or other foreign matter or energy, or (iv) repair or damage caused by anyone except personnel authorized by Company. Products repaired or replaced and designs corrected under warranty are warranted only for the remainder of the original warranty period if a time limitation has been given. Any general product literature is for illustrative purposes only and does not amount to a warranty of any kind. Purchaser accepts full responsibility for the selection of the Products to achieve intended results.

THIS LIMITED WARRANTY AS SET FORTH HEREIN IS STRICTLY LIMITED TO ITS TERMS AND IS IN LIEU OF ALL OTHER WARRANTIES, GUARANTEES, EXPRESS OR IMPLIED, ARISING BY OPERATION OF LAW, COURSE OF DEALING, USAGE OF TRADE OR OTHERWISE, ANY IMPLIED WARRANTIES INCLUDING BUT NOT LIMITED TO ANY IMPLIED WARRANTIES OF MERCHANTABILITY OR FITNESS FOR A PARTICULAR PURPOSE SHALL BE LIMITED IN DURATION TO THE WARRANTY PERIODS OF TIME SET FORTH ABOVE.

REMEDY. PURCHASER'S SOLE AND EXCLUSIVE REMEDY UNDER THIS LIMITED WARRANTY OR ANY OTHER WARRANTY (INCLUDING ANY IMPLIED WARRANTY), AND COMPANY'S ONLY OBLIGATION FOR BREACH OF WARRANTY FOR PRODUCTS FURNISHED HEREUNDER, SHALL BE, AT COMPANY'S OPTION, TO REPAIR OR REPLACE THE DEFECTIVE ITEM(S) OR PART(S) WHICH FAIL WITHIN THE DESIGNATED WARRANTY TIME PERIOD, FREE OF CHARGE, provided that Purchaser promptly give notice, but no later than 30 days after defect(s) is discovered, to Company of such failure. In the event Purchaser claims that the Products are defective, Purchaser must return such Products to Company, prepaid FOB, to allow Company to examine the Products to determine if such Products are defective. In addition, upon Company's request, Purchaser must allow Company's personnel access and permission to inspect the Products at the site of installation or use. NOTWITHSTANDING THIS WARRANTY, UNDER ALL CIRCUMSTANCES, PURCHASER IS RESPONSIBLE FOR THE COSTS OF REMOVAL, INSTALLATION OR REINSTALLATION OF THE PRODUCT.

DISCLAIMER: LIMITATION OF LIABILITY ' TIME FOR CLAIMS. Purchaser understands and agrees that COMPANY SHALL NOT BE LIABLE FOR INCIDENTAL, SPECIAL, INDIRECT OR CONSEQUENTIAL OR OTHER SIMILAR DAMAGES including but not limited to loss of profit or revenues, damage for loss of the use of the products, damages due to delay, damage to property, claims of third parties, including personal injury or death suffered as a result of use of products or failure of Company to warn, or to adequately warn, against the dangers of the products or to instruct, or adequately instruct, about the safe and proper use of the products, whether or not the Company has been advised to the potential for such damages. The total liability of Company to Purchaser from any cause whatsoever, whether arising under contract, warranty, tort (including negligence), strict liability, products liability or any other theory of liability, will be limited to the lesser of Purchaser's actual damages or the purchase price paid to Company for the products that are the subject of Purchaser's claim. However, this limitation of liability does not apply to damages resulting from personal injury caused by Company's negligence. All claims against Company must be brought within one year after the cause of action arises, and Purchaser expressly waives any statute of limitations which might apply by operation of law or otherwise.

COMPANY SHALL NOT BE LIABLE FOR ANY DAMAGE OR PENALTIES WHATSOEVER, WHETHER, DIRECT, INDIRECT, INCIDENTAL, SPECIAL OR CONSEQUENTIAL, FOR ACTIONS AND OMISSIONS RESULTING FROM COMPANY'S FAILURE TO DELIVER OR DELAY IN DELIVERY FOR ANY REASON.

CLAIMS FOR WARRANTY SERVICE

To obtain warranty service, Purchaser must notify company and the dealer which sold the product in writing of the nature of the problem. In the written notice, Purchaser must include its name, address, telephone number, a description of the problem and the date on which the problem first occurred. A bill of sale, canceled check, receipt or other proof of purchase also must be provided to verify the date of purchase and the identity of the Purchaser. In some cases, Company may require Purchaser to ship the defective part(s), transportation or other related charges prepaid, to the nearest warranty service factory location. Purchaser must contact Company and the dealer that sold the Product as soon as possible, but no later than 30 days, after the defect(s) is discovered. If Purchaser has any problems with or questions about warranty service, please write Sunteca Systems, Inc. at Avenue A, Building # 2, Leetsdale, PA 15056.

REPLACEMENT PARTS. Replacement parts supplied by Company under this Limited Warranty are not warranted.

RESALE OF PRODUCTS. Upon resale of any Products sold hereunder, Purchaser agrees to extend to its customers no greater warranties than those contained herein and limit its liability and remedies to the same extent as those set forth herein.

SEPARABILITY; INVALIDITY. If any portion of this Limited Warranty shall for any reason be held by a court of competent jurisdiction to be invalid and unenforceable, the valid and enforceable provisions will continue to be given effect and bind parties hereto.